



APPLICATION

The FRANCIS FSP250 Signalling Searchlight incorporates the features required to successfully operate searchlights in the most demanding product operating environments on land and sea. The 250mm (10") pedestal or bridge wing mounted light is used on medium and large craft for ship to ship and ship to shore signalling using the morse code or similar signalling code.

The light is all brass, anti-magnetic construction and is fully weatherproof.

The light shutter can be locked to allow its use as a searchlight.

SPECIFICATION

- 250mm (10")~ Signalling Projector
- Weatherproof (IP56)
- Signaling range minimum of 10 miles / 16 km (daylight)
- Signalling speed of 12 words per minute
- Lamp options : 1000w halogen in both 115v & 230v
- Lamp life 240v - 200 hrs and 115v - 250 hrs
- Beam divergence of 6° degrees
- Vertical movement + 60° to -45°
- Searchlight weight 33Kgs
- Pedestal weight 11.5Kgs

Part Numbers

Type	Supply	Part No	NSN No:
FSP250	115/230v	A4047	5850-99-799-7340
1000w G22 Lamp	115v	D24418	6240-99-340-5216
1000w G22 Lamp	230v	D24415	6240-99-464-5106
Pedestal Assy		C03323-01	6230-99-462-4137
Waterproof cover		C02040-00	
Amber Filter Assy		C14194-01	
Green Filter Assy		C14336-01	
Yellow Filter Assy		C14195-01	
Red Filter Assy		C06244-01	

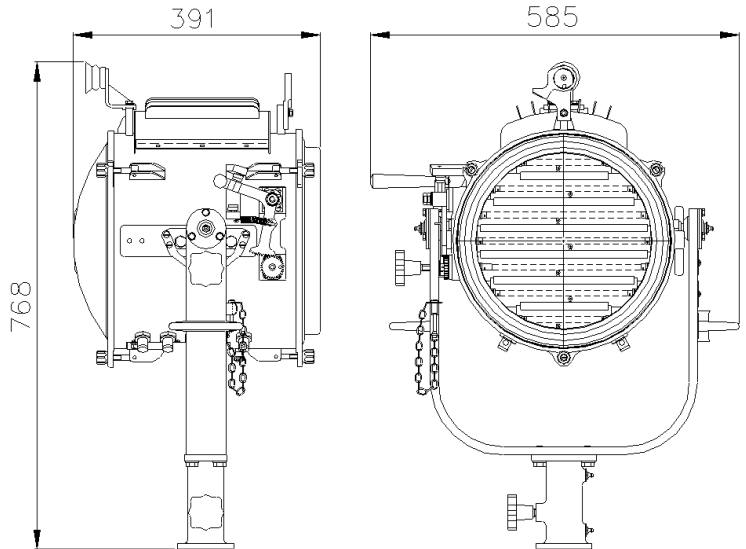

ALL DIMENSIONS IN MILLIMETRES

Pedestal: 3 holes Ø14.30 on a 190.5 PCD

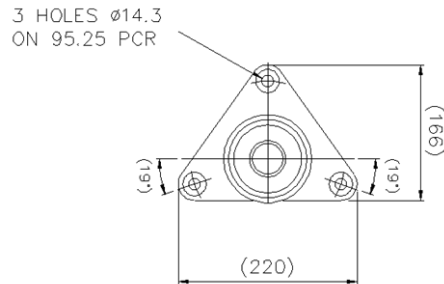

For more information contact: