



FSP380 Issue 5
CSI light source
Signalling 380mm

APPLICATION

The FRANCIS FSP380 Signalling Searchlight incorporates the features required to successfully operate searchlights in the most demanding product operating environments on land and sea.

The 380mm (15") pedestal or bridge wing mounted light is used on medium and large craft for ship to ship and ship to shore signalling using the morse code or similar signalling code.

The light is manufactured in brass, an anti-magnetic construction and is fully weatherproof. The light shutter can be locked to allow its use as a searchlight.

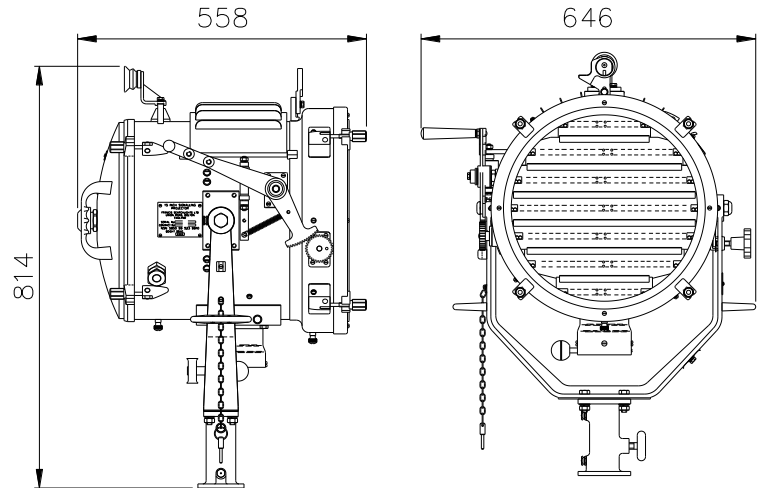

SPECIFICATION

- 380mm (15") Signalling Projector
- Weatherproof (IP56)
- Signaling range minimum of 12 miles / 19.44 km (daylight)
- Signalling speed of 12 words per minute
- Lamp options : Quartz Iodide CSI 400w
- Lamp cap G22 medium bi-post
- Lamp life 500 hrs
- Beam divergence of 4° degrees
- Vertical movement + 60° to -45°
- FSP380 weight 51Kgs
- Pedestal Assy weight 10.5Kgs

Control unit

- Aluminium casing
- Weatherproof (IP56)
- Input 440v / 60 hz 2 Ph 5/8 Amp
- Weight 35.5Kgs

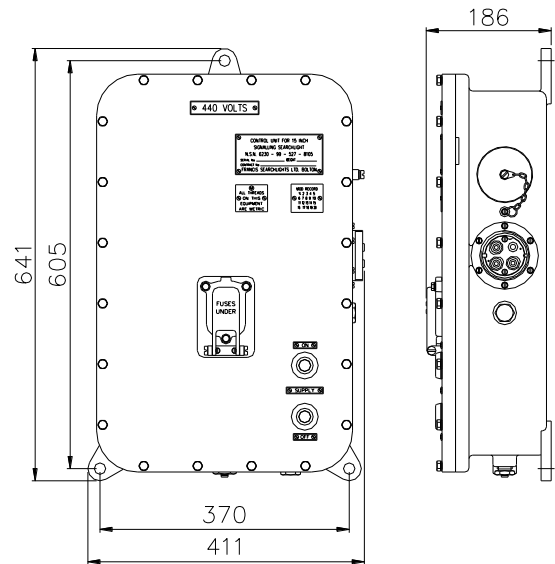

Part Numbers

Type	Supply	Part No	NSN No:
FSP380	440v	A4197	5850-99-523-9810
Control Unit Assy	440v	A4195	6230-99-527-8105
400w CSI Lamp	440v	D8428	6240-99-766-3716
Pedestal Assy		C06622-01	6230-99-529-1168
Waterproof cover		C05433-00	5895-99-780-0859
15" Plug Assy		C14553-00	5935-99-419-7500

For more information contact:

Francis Searchlights Limited
Union Road, Bolton, BL2 2HJ, UK
Tel 44 (0) 1204 558960 Fax 44 (0) 1204 558979
Email sales@francis.co.uk Web site www.francis.co.uk