



SL-15
with User-Adjustable Flash Settings
1–2NM+ Solar Marine Light
Installation & Service Manual

SL-15

with User-Adjustable Flash Settings

1-2NM+ Solar Marine Light

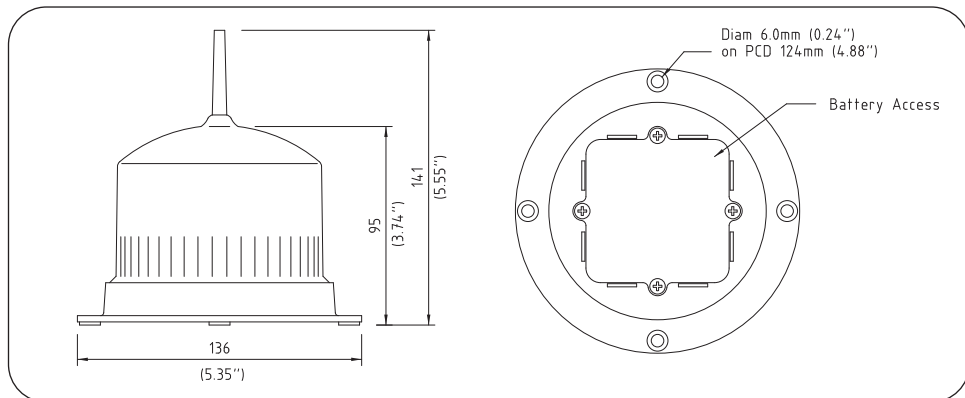
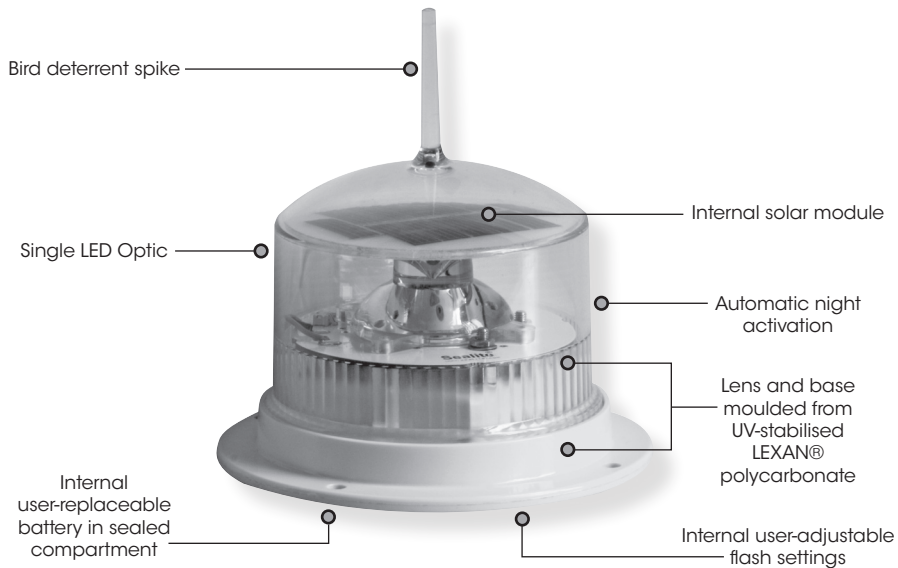

Table of Contents

Introduction	Page 4
Operating Principle	Page 4
Technology	Page 4
SL-15 Model	Page 5
Installation	Page 6
Flash Codes	Page 6
Flash Code Table	Page 8
IR Remote	Page 14
Maintenance and Servicing	Page 19
Trouble Shooting	Page 20
Optional ON/OFF Switch	Page 21
SL-15 Accessories	Page 22
Sealite LED Light Warranty	Page 23

Version No.	Description	Date	Author	Approved
1.0	Manual re-launch	June 2009	K. Paton	
2.0	Flash Adjustment	July 2009	K. Paton	
2.1	Logo Update	May 2010	K. Paton	
2.2	Warranty Update	July 2010	K. Paton	
3.0	Update: New Design	Sept 2011	J. Dore	
3.1	General update	June 2012	J. Dore	
3.2	Update: Replacing the battery	July 2012	J. Dore	
3.3	External switch operation	December 2015	Y. Chambers	
3.4	Update: Contact details	January 2016	J. Dore	
3.5	Update: Battery details	October 2016	M.Asiam	M.Nicholson
3.7	Battery charging advice	October 2020	M.Dutka	M.Nicholson

Introduction

Congratulations! By choosing to purchase a Sealite lantern you have become the owner of one of the most advanced LED marine lanterns in the world.

Sealite Pty Ltd has been manufacturing lanterns for over 25 years, and particular care has been taken to ensure your lantern gives years of service.

As a commitment to producing the highest quality products for our customers, Sealite has been independently certified as complying with the requirements of ISO9001:2015 quality management system.

Sealite lanterns comply with requirements of the US Coast Guard in 33 CFR part 66 for Private Aids To Navigation.

By taking a few moments to browse through this booklet, you will become familiar with the versatility of your lantern, and be able to maximise its operating function.

Operating Principle

The solar module of the lantern converts sunlight to an electrical current that is used to charge the battery. The battery provides power to operate the lantern at night.

The flasher unit has very low current requirements. A microprocessor drives an ultra bright LED through a DC/DC converter, which enables the LED's to operate within the manufacturer's specifications. The battery is protected from over-charging within the circuit to ensure maximum battery life.

On darkness, the microprocessor will initiate a program check and after approximately 1 minute begin flashing to the set code

Technology

Sealite is the world's fastest growing manufacturer of marine aids to navigation. We employ leading mechanical, optical, hardware & software engineers to create innovative products to service the needs of our customers worldwide, and offer the widest range of solar-powered LED lanterns in the marketplace.

Electronics

Sealite employs leading in-house electronic engineers in the design and development of software and related circuitry. All individual electronic components are sourced directly by Sealite procurement staff ensuring that only the highest quality components are used in our products.

LED Technology

All marine lanterns use the latest advancements in LED (Light Emitting Diode) technology as a light source. The major advantage of LED's over traditional light sources is well established in that they typically have an operational life in excess of 100,000 hours, resulting in substantial savings to maintenance and servicing costs.

Precision Construction

Commitment to investing in the design and construction of injection-moulded parts including optic lenses, light bases and a range of other components ensures that all Sealite products are of a consistent & superior quality.

Optical Performance

Sealite manufactures a range of marine LED lenses moulded from multi-cavity dies. Complex shapes such as the SL-70, BargeSafe™ and 16-segment multi-focus lenses are a testament to the company's superior in-house lens manufacturing capabilities and outstanding optical performance.

Award-winning, Patented Technology

Several United States and Australian patent registrations are held on Sealite's range of innovative designs, with other regional patents pending in Canada, United Kingdom and Europe.

SL-15 Model

The Sealite SL-15 1-2NM+ LED compact light incorporates some of the most advanced technology available. Made from tough, durable polycarbonate and using the latest high-intensity LEDs, no expense has been spared in the design and development of this lantern. Installation takes just minutes, and a permanent ON/OFF, accessible through the battery compartment, switch allows for easy storage. The SL-15 is designed to be maintenance-free and have a service life of over 3 years.

SPECIFICATIONS* *

SL-15

Light Characteristics

Light Source
Available Colours
Typical Maximum Intensity (cd)†
Visible Range (NM)

LED
Red, Green, White, Yellow, Blue
Red - 6.2 Green - 7.6 White - 6.8 Yellow - 5.9
AT @ 0.74: 1-2+
AT @ 0.85: 1.1-2.3+

Horizontal Output (degrees)
Vertical Divergence (degrees)
Reflector Type
Available Flash Characteristics

360
7
Single LED Optic
16 user-adjustable IALA flash characteristics (other flash patterns available on request)
32 automatic step-down settings based on power demand of flash code selection
>100,000

Intensity Adjustments

LED Life Expectancy (hours)

Electrical Characteristics

Current Draw (mA)
Circuit Protection
Nominal Voltage (V)
Autonomy (days)
Temperature Range

Refer to Sealite Power Calculator
Integrated
3.6
>50 (14 hour darkness, 12.5% duty cycle)
-40 to 80°C

Solar Characteristics

Solar Module Type
Output (watts)

Multicrystalline
0.45

Power Supply

Battery Type
Battery Capacity (Ah)
Nominal Voltage (V)

High grade NiMH
2.4
3.6

Physical Characteristics

Body Material
Lens Material
Lens Diameter (mm/inches)
Lens Design
Mounting
Height (mm/inches)
Width (mm/inches)
Mass (kg/lbs)
Product Life Expectancy

LEXAN® Polycarbonate - UV-stabilised
LEXAN® Polycarbonate - UV-stabilised
98 / 3⁷/₈
Single LED Optic
4 x 6mm mounting holes
141 / 5¹/₂
136 / 5³/₈
0.5 / 1¹/₈
Up to 12 years

Certifications

CE
IALA
Quality Assurance
Waterproof

EN61000-6-3:1997. EN61000-6-1:1997
Signal colours compliant to IALA E-200-1
ISO9001:2015
IP68

Intellectual Property

Patents
Trademarks

US Pat. No. 6,667,582. AU Pat. No. 778,918
SEALITE® is a registered trademark of Sealite Pty Ltd
3 years

Warranty*

Options Available

- ON/OFF switch
- Custom flash patterns
- 50mm pole mount adapter plate

• Specifications subject to change or variation without notice
* Subject to standard terms and conditions
† Intensity setting subject to solar availability



Installation

Charging the Battery

New lanterns should be left in the sun for 1-2 days to ensure battery is charged before placing in service. Please note, lantern will re-charge even when switch is turned to 'OFF' position.

Preferred Installation Location

For best lantern performance, ensure solar modules are not covered and are in clear view of the sky with no shadows.

1. The SL-15 will be supplied preset to the requested flash code.
2. The light can be directly positioned in your desired location. Secure it, utilising the 4 x holes in the flange. Ensure the light is bolted to an even, flat surface.

Flash Codes

Adjusting the Flash Code

1. Remove the 4 x battery cover screws and lift the cover and battery out of the compartment to expose the adjustment plug.
2. Unscrew the adjustment plug.
3. Using a small flat bladed screwdriver adjust the Flash Code to the desired setting.
4. Cover the light, in darkness, for at least 30 seconds to activate the light sensor. Make sure the light is flashing correctly.
5. Uncover the light and wait at least 30 seconds to make sure the light turns off in daylight.
6. Insert the adjustment plug and replace the battery.
7. Replace the cover and secure using the 4 x screws. Do Not over tighten screws.
8. Position the light in your desired location and secure, utilising the 4 x holes in the flange. Ensure the light is bolted to an even, flat surface.

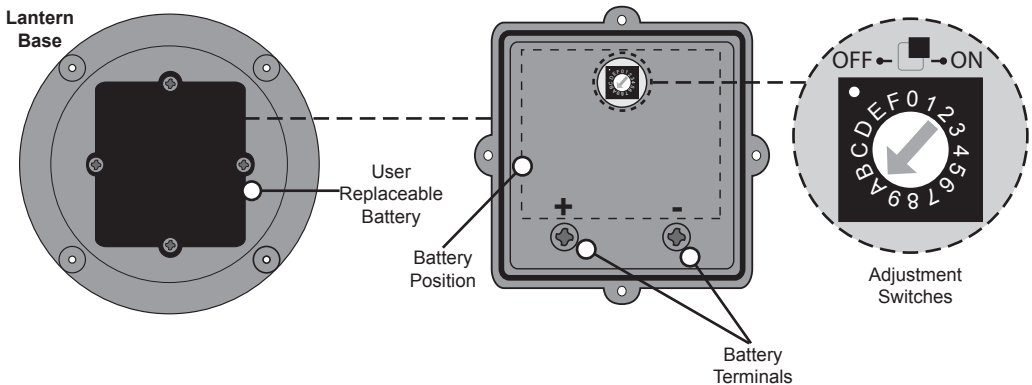

Selecting an Intensity/Power Setting

Using the latest technology in software, the SL-15 automatically adjusts the Intensity Setting when Flash Code is set.

Selecting a Flash Code- Rotary Switch

All SL-15 Lights are fitted with a rotary switch. Turning the small arrow to the appropriate number or letter will set the code (see '*Flash Codes*' section of this manual). The unit may take up to one minute to activate a new flash code. A comprehensive list of available flash codes is listed in the '*Flash Code Table*' section of this manual.

Rotary
Switch



Flash Code Table

Sealite marine lanterns may be set to any of IALA recommended flash settings. These can be set via rotary switches inside the lantern or the IR remote or via the Sealite Configuration Tool.

SEALITE® code reference is listed by number of flashes

**For the latest version of this document visit www.sealite.com
or email info@sealite.com**

Symbols

FL	Flash followed by number Eg. FL 1 S, one flash every second
F	Fixed
Q	Quick flash
VQ	Very quick flash
OC	Occulting; greater period on than off
ISO	Isophase; equal period on and off
LFL	Long flash long
MO	Morse code () contains letter

For example, VQ (6) + LFL 10 S means 6 very quick flashes followed by a long flash, during a 10-second interval.

The amount of power your lantern draws through the night depends on the duty cycle, i.e. the amount of time on as a proportion to the timing cycle. For example, 0.5 seconds on and 4.5 seconds off equals a 10% duty cycle.

It is best to operate at the lowest duty cycle appropriate to the actual needs of the application.

Recommended Rhythm for Flashing Light - IALA Regions A and B

MARK DESCRIPTION	RHYTHM
Port Hand & Starboard Marks:	Any, other than Composite Group Flashing (2+1)
Preferred Channel Starboard:	Composite Group Flashing (2+1)
Preferred Channel Port:	Composite Group Flashing (2+1)
North Cardinal Mark:	Very quick or quick
East Cardinal Mark:	Very quick (3) every 5 seconds or quick (3) every 10 seconds
South Cardinal Mark:	Very quick (6) + long flash every 10 seconds or quick (6) + long flash every 15 seconds
West Cardinal Mark:	Very quick (9) every 10 seconds or quick (9) every 15 seconds
Isolated Danger Mark:	Group flashing (2)
Safe Water Mark:	Isophase, occulting, one long flash every 10 seconds or Morse Code "A"
Special Marks:	Any, other than those described for Cardinal, Isolated Danger or Safe Water Marks

SWITCH	IR Controller	FLASH CODE	ON	OFF
A				
0	0	F (Steady light)		
-	211	VQ 0.5 S	0.2	0.3
-	274	VQ 0.5 S	0.25	0.25
-	227	VQ 0.6 S	0.2	0.4
-	243	VQ 0.6 S	0.3	0.3
-	115	Q 1 S	0.2	0.8
5	131	Q 1 S	0.3	0.7
-	147	Q 1 S	0.4	0.6
-	163	Q 1 S	0.5	0.5
-	132	Q 1 S	0.8	0.2
-	179	Q 1.2 S	0.3	0.9
-	293	FL 1.2 S	0.4	0.8
-	148	Q 1.2 S	0.5	0.7
-	195	Q 1.2 S	0.6	0.6
-	244	FL 1.5 S	0.2	1.3
-	16	FL 1.5 S	0.3	1.2
-	5	FL 1.5 S	0.4	1.1
1	4	FL 1.5 S	0.5	1.0
-	32	FL 2 S	0.2	1.8
7	48	FL 2 S	0.3	1.7
-	64	FL 2 S	0.4	1.6
-	80	FL 2 S	0.5	1.5
-	96	FL 2 S	0.7	1.3
-	112	FL 2 S	0.8	1.2
-	18	ISO 2 S	1.0	1.0
8	128	FL 2.5 S	0.3	2.2
9	144	FL 2.5 S	0.5	2.0
-	214	FL 2.5 S	1.0	1.5
-	21	FL 3 S	0.2	2.8
A	160	FL 3 S	0.3	2.7
-	37	FL 3 S	0.4	2.6
B	176	FL 3 S	0.5	2.5
-	53	FL 3 S	0.6	2.4
C	192	FL 3 S	0.7	2.3
-	208	FL 3 S	1.0	2.0
-	34	ISO 3 S	1.5	1.5
-	84	OC 3 S	2.0	1.0
-	226	OC 3 S	2.5	0.5
-	70	OC 3.5 S	2.5	1.0
-	69	FL 4 S	0.2	3.8
-	85	FL 4 S	0.3	3.7
-	224	FL 4 S	0.4	3.6
2	240	FL 4 S	0.5	3.5
-	101	FL 4 S	0.6	3.4
-	1	FL 4 S	0.8	3.2
-	17	FL 4 S	1.0	3.0
-	33	FL 4 S	1.5	2.5
-	50	ISO 4 S	2.0	2.0
-	54	OC 4 S	2.5	1.5
-	242	OC 4 S	3.0	1.0
-	49	FL 4.3 S	1.3	3.0
-	133	FL 5 S	0.2	4.8
-	65	FL 5 S	0.3	4.7
-	279	FL 5 S	0.4	4.6
D	81	FL 5 S	0.5	4.5
-	149	FL 5 S	0.9	4.1
E	97	FL 5 S	1.0	4.0
	113	FL 5 S	1.5	3.5

SWITCH	IR Controller	FLASH CODE	ON	OFF
A				
-	66	ISO 5 S	2.5	2.5
-	130	LFL 5 S	2.0	3.0
-	3	OC 5 S	3.0	2.0
-	19	OC 5 S	4.0	1.0
-	35	OC 5 S	4.5	0.5
-	198	FL 6 S	0.2	5.8
-	181	FL 6 S	0.3	5.7
-	197	FL 6 S	0.4	5.6
4	129	FL 6 S	0.5	5.5
-	145	FL 6 S	0.6	5.4
-	161	FL 6 S	1.0	5.0
-	117	FL 6 S	1.2	4.8
-	177	FL 6 S	1.5	4.5
-	82	ISO 6 S	3.0	3.0
-	146	LFL 6 S	2.0	4.0
-	100	OC 6 S	4.0	2.0
-	51	OC 6 S	4.5	1.5
-	67	OC 6 S	5.0	1.0
-	280	FL 7 S	0.4	6.6
-	164	FL 7 S	1.0	6.0
-	150	FL 7 S	2.0	5.0
-	86	OC 7 S	4.5	2.5
-	213	FL 7.5 S	0.5	7.0
-	193	FL 7.5 S	0.8	6.7
-	229	FL 8 S	0.5	7.5
-	180	FL 8 S	1.0	7.0
-	98	ISO 8 S	4.0	4.0
-	162	LFL 8 S	2.0	6.0
-	102	OC 8 S	5.0	3.0
-	294	OC 8 S	6.0	2.0
-	178	LFL 8 S	3.0	5.0
-	245	FL 9 S	0.9	8.1
-	196	FL 9 S	1.0	8.0
-	118	OC 9 S	6.0	3.0
-	6	FL 10 S	0.2	9.8
-	22	FL 10 S	0.3	9.7
-	281	FL 10 S	0.4	9.6
-	209	FL 10 S	0.5	9.5
-	38	FL 10 S	0.8	9.2
-	225	FL 10 S	1.0	9.0
-	20	FL 10 S	1.5	8.5
-	194	LFL 10 S	2.0	8.0
-	210	LFL 10 S	3.0	7.0
-	114	ISO 10 S	5.0	5.0
-	36	LFL 10 S	4.0	6.0
-	134	OC 10 S	6.0	4.0
-	83	OC 10 S	7.0	3.0
-	99	OC 10 S	7.5	2.5
-	303	FL 11 S	1.0	10.0
-	302	FL 12 S	1.0	11.0
-	241	FL 12 S	1.2	10.8
-	212	FL 12 S	2.5	9.5
-	52	LFL 12 S	2.0	10.0
-	2	FL 15 S	1.0	14.0
-	68	LFL 15 S	4.0	11.0
-	116	OC 15 S	10	5.0
-	166	LFL 20 S	2.0	18.0
	228	FL 26 S	1.0	25.0

SWITCH	IR Controller	FLASH CODE	ON	OFF	ON	OFF
A						
-	10	FL (2) 4 S	0.5	1.0	0.5	2.0
-	235	VQ (2) 4 S	0.2	1.0	0.2	2.6
-	26	FL (2) 4.5 S	0.3	1.0	0.3	2.9
-	42	FL (2) 4.5 S	0.4	1.0	0.4	2.7
-	58	FL (2) 4.5 S	0.5	1.0	0.5	2.5
-	277	FL (2) 4.6 S	0.3	0.3	0.3	3.7
-	249	FL (2) 5 S	0.2	0.8	0.2	3.8
-	44	FL (2) 5 S	0.2	1.2	0.2	3.4
-	74	FL (2) 5 S	0.4	0.6	0.4	3.6
-	282	FL (2) 5 S	0.4	1.1	0.4	3.1
-	7	FL (2) 5 S	0.5	1.0	0.5	3.0
-	23	FL (2) 5 S	1.0	1.0	1.0	2.0
-	257	FL (2) 5 S	0.3	1.0	0.3	3.4
-	155	Q (2) 5 S	0.3	0.7	0.3	3.7
-	41	Q (2) 5 S	0.5	0.5	0.5	3.5
-	305	FL (2) 5 S	0.5	0.7	0.5	3.3
-	90	FL (2) 5.5 S	0.4	1.4	0.4	3.3
-	120	FL (2) 6 S	0.3	0.6	1.0	4.1
-	170	FL (2) 6 S	0.3	0.9	0.3	4.5
-	106	FL (2) 6 S	0.3	1.0	0.3	4.4
-	122	FL (2) 6 S	0.4	1.0	0.4	4.2
-	283	FL (2) 6 S	0.4	1.2	0.4	4.0
-	153	FL (2) 6 S	0.5	1.0	0.5	4.0
-	40	FL (2) 6 S	0.8	1.2	0.8	3.2
-	256	FL (2) 6 S	0.8	0.8	0.8	3.6
-	55	FL (2) 6 S	1.0	1.0	1.0	3.0
-	57	Q (2) 6 S	0.3	0.7	0.3	4.7
-	295	LFL + FL 6 S	3.0	1.0	1.0	1.0
-	273	FL (2) 6.5 S	0.5	1.0	0.5	4.5
-	283	FL (2) 7 S	0.4	1.2	0.4	5.0
-	311	FL (2) 7 S	0.5	1.5	0.5	4.5
-	169	FL (2) 7 S	1.0	1.0	1.0	4.0
-	123	FL (2) 8 S	0.4	0.6	2.0	5.0
-	138	FL (2) 8 S	0.4	1.0	0.4	6.2
-	285	FL (2) 8 S	0.4	1.7	0.4	5.5
-	71	FL (2) 8 S	0.5	1.0	0.5	6.0
-	297	FL (2) 8 S	0.5	0.5	1.5	5.5
-	136	FL (2) 8 S	0.8	1.2	2.4	3.6
-	87	FL (2) 8 S	1.0	1.0	1.0	5.0
-	76	OC (2) 8 S	3.0	2.0	1.0	2.0
-	92	OC (2) 8 S	5.0	1.0	1.0	1.0
-	251	VQ (2) 8 S	0.2	1.0	0.2	6.6
-	286	FL (2) 9 S	0.4	1.7	0.4	6.5
-	154	FL (2) 10 S	0.4	1.6	0.4	7.6
-	287	FL (2) 10 S	0.4	2.2	0.4	7.0
-	103	FL (2) 10 S	0.5	1.0	0.5	8.0
-	119	FL (2) 10 S	0.5	1.5	0.5	7.5
-	105	FL (2) 10 S	0.5	2.0	0.5	7.0
-	298	FL (2) 10 S	0.5	0.5	1.5	7.5
-	135	FL (2) 10 S	0.8	1.2	0.8	7.2
-	185	FL (2) 10 S	1.0	1.0	1.0	7.0
-	151	FL (2) 10 S	1.0	1.5	1.0	6.5
-	73	Q (2) 10 S	0.6	0.4	0.6	8.4
-	186	FL (2) 12 S	0.4	1.0	0.4	10.2
-	201	FL (2) 12 S	0.5	1.0	0.5	10.0
-	217	FL (2) 12 S	1.5	2.0	1.5	7.0
-	168	FL (2) 15 S	0.5	1.5	2.0	11.0
-	167	FL (2) 15 S	1.0	2.0	1.0	11.0
-	139	Q (2) 15 S	0.2	0.8	0.2	13.8
-	202	FL (2) 20 S	1.0	3.0	1.0	15.0
-	218	FL (2) 25 S	1.0	1.0	1.0	22.0

SWITCH	IR Controller	FLASH CODE	ON	OFF	ON	OFF	ON	OFF
A								
-	121	Q (3) 5 S	0.5	0.5	0.5	0.5	0.5	2.5
-	89	VQ (3) 5 S	0.2	0.3	0.2	0.3	0.2	3.8
-	12	VQ (3) 5 S	0.3	0.2	0.3	0.2	0.3	3.7
-	233	VQ (3) 5 S	0.3	0.3	0.3	0.3	0.3	3.5
-	308	FL (3) 5 S	0.3	0.7	0.3	0.7	0.3	3.7
-	60	FL (3) 6 S	0.5	1.0	0.5	1.0	0.5	2.5
-	43	FL (2+1) 6 S	0.3	0.4	0.3	1.2	0.3	3.5

SWITCH	IR		ON	OFF	ON	OFF	ON	OFF
	Controller	FLASH CODE						
A								
-	171	Q (3) 6 S	0.3	0.7	0.3	0.7	0.3	3.7
-	250	FL (3) 8 S	0.5	1.0	0.5	1.0	0.5	4.5
-	301	FL (3) 8 S	1.5	0.5	0.5	0.5	0.5	4.5
-	266	Q (3) 9 S	0.5	0.5	0.5	1.0	0.5	6.0
-	11	FL (3) 9 S	0.3	1.0	0.3	1.0	0.3	6.1
-	306	FL (3) 9 S	0.5	1.5	0.5	1.5	0.5	4.5
-	183	FL (3) 9 S	0.8	1.2	0.8	1.2	0.8	4.2
-	184	FL (3) 10 S	0.3	0.7	0.3	0.7	0.9	7.1
-	200	FL (3) 10 S	0.4	0.6	0.4	0.6	1.2	6.8
-	290	FL (3) 10 S	0.4	0.8	0.4	0.8	0.4	7.2
-	203	FL (3) 10 S	0.5	0.5	0.5	0.5	0.5	7.5
-	199	FL (3) 10 S	0.5	1.5	0.5	1.5	0.5	5.5
-	219	FL (3) 10 S	0.6	0.6	0.6	0.6	0.6	7.0
-	278	FL (3) 10 S	0.9	1.1	0.9	1.1	0.9	5.1
-	215	FL (3) 10 S	1.0	1.0	1.0	1.0	1.0	5.0
-	261	FL (3) 10 S	0.35	0.65	0.35	0.65	0.35	7.65
-	56	FL (2+1) 10 S	0.5	0.7	0.5	2.1	0.5	5.7
-	137	OC (3) 10 S	5.0	1.0	1.0	1.0	1.0	1.0
-	187	Q (3) 10 S	0.3	0.7	0.3	0.7	0.3	7.7
-	216	FL (2 + 1) 10 S	0.5	0.5	0.5	0.5	1.5	6.5
-	288	FL (3) 12 S	0.4	2.1	0.4	2.1	0.4	6.6
-	27	FL (3) 12 S	0.5	1.5	0.5	1.5	0.5	7.5
-	234	FL (3) 12 S	0.5	2.0	0.5	2.0	0.5	6.5
-	231	FL (3) 12 S	0.8	1.2	0.8	1.2	0.8	7.2
-	182	FL (3) 12 S	1.0	1.0	1.0	3.0	1.0	5.0
-	72	FL (2+1) 12 S	0.8	1.2	0.8	2.4	0.8	6.0
-	88	FL (2+1) 12 S	1.0	1.0	1.0	4.0	1.0	4.0
-	272	FL (3) 12.5 S	0.5	1.0	0.5	1.0	0.5	9.0
-	289	FL (3) 13 S	0.4	2.1	0.4	2.1	0.4	7.6
-	296	LFL + FL(2) 13 S	6.0	1.0	2.0	1.0	2.0	1.0
-	24	FL (2+1) 13.5 S	1.0	1.0	1.0	4.0	1.0	5.5
-	307	FL (3) 14.5 S	0.5	1.0	1.5	3.0	0.5	9.0
-	247	FL (3) 15 S	0.3	1.7	0.3	1.7	0.3	10.7
-	157	FL (3) 15 S	0.4	1.0	0.4	1.0	0.4	11.8
-	8	FL (3) 15 S	0.5	1.5	0.5	1.5	0.5	10.5
-	259	FL (3) 15 S	0.5	2.0	0.5	2.0	0.5	9.5
-	260	FL (3) 15 S	1.0	1.0	1.30	1.0	1.0	10.0
-	248	FL (2+1) 15 S	0.6	0.3	0.6	0.3	1.4	11.8
-	9	FL (2+1) 15 S	0.7	0.5	0.7	0.5	1.9	10.7
-	25	FL (2+1) 15 S	0.7	0.7	0.7	0.7	2.1	10.1
-	104	FL (2+1) 15 S	1.0	2.0	1.0	5.0	1.0	5.0
-	265	FL (2+1) 15 S	1.3	0.7	1.3	0.7	3.3	7.7
-	264	FL (2+1) 15.75 S	0.55	0.35	0.55	0.35	1.45	12.5
-	28	VQ (3) 15 S	0.1	0.5	0.1	0.5	0.1	13.7
-	313	FL (2) + LFL 16 S	2.0	2.0	2.0	2.0	6.0	2.0
-	75	FL (3) 20 S	0.5	3.0	0.5	3.0	0.5	12.5
-	59	FL (3) 20 S	0.5	1.5	0.5	1.5	0.5	15.5
-	263	FL (3) 20 S	0.5	2.0	0.5	2.0	0.5	12.0
-	91	FL (3) 20 S	0.8	1.2	0.8	1.2	0.8	15.2
-	107	FL (3) 20 S	1.0	1.0	1.0	1.0	1.0	15.0

SWITCH	IR		ON	OFF	ON	OFF	ON	OFF	ON	OFF
	Controller	FLASH CODE								
A										
-	271	VQ (4) 2 S	0.10	0.13	0.10	0.13	0.10	0.13	0.10	1.21
-	191	VQ (4) 4 S	0.3	0.3	0.3	0.3	0.3	0.3	0.3	2.3
-	189	Q (4) 6 S	0.3	0.7	0.3	0.7	0.3	0.7	0.3	2.7
-	141	Q (4) 6 S	0.4	0.6	0.4	0.6	0.4	0.6	0.4	2.6
-	299	FL (1+3) 8 S	1.5	0.5	0.5	0.5	0.5	0.5	0.5	3.5
-	309	FL (4) 7 S	0.3	0.7	0.3	0.7	0.3	0.7	0.3	3.7
-	29	FL (4) 10 S	0.5	1.0	0.5	1.0	0.5	1.0	0.5	5.0
-	45	FL (4) 10 S	0.8	1.2	0.8	1.2	0.8	1.2	0.8	3.2
-	254	Q (4) 10 S	0.3	0.7	0.3	0.7	0.3	0.7	0.3	6.7
-	300	FL (4) 10 S	1.5	0.5	0.5	0.5	0.5	0.5	0.5	4.5
-	312	FL (4) 11 S	0.5	1.5	0.5	1.5	0.5	1.5	0.5	4.5
-	190	FL (4) 12 S	0.3	1.7	0.3	1.7	0.3	1.7	0.3	5.7
-	79	FL (4) 12 S	0.5	0.5	0.5	0.5	0.5	0.5	0.5	8.5
-	206	FL (4) 12 S	0.5	1.5	0.5	1.5	0.5	1.5	0.5	5.5
-	61	FL (4) 12 S	0.8	1.2	0.8	1.2	0.8	1.2	0.8	5.2
-	173	Q (4) 12 S	0.3	0.7	0.3	0.7	0.3	0.7	0.3	8.7
-	77	FL (4) 15 S	0.5	1.5	0.5	1.5	0.5	1.5	0.5	8.5
-	142	FL (4) 15 S	1.0	1.0	1.0	1.0	1.0	1.0	1.0	8.0
-	125	FL (4) 15 S	1.5	0.5	0.5	0.5	0.5	0.5	0.5	10.5
-	222	FL (4) 16 S	0.5	1.5	0.5	1.5	0.5	1.5	0.5	9.5
-	314	FL (3+1) 18 S	1.5	1.5	1.5	1.5	1.5	4.5	1.5	4.5
6	304	FL (4) 19 S	0.3	0.7	0.3	0.7	0.3	0.7	0.3	15.7
-	205	FL (4) 20 S	0.3	3.0	0.3	3.0	0.3	3.0	0.3	9.8
-	93	FL (4) 20 S	0.5	1.5	0.5	1.5	0.5	1.5	0.5	13.5
-	13	FL (4) 20 S	0.5	1.5	0.5	1.5	0.5	4.5	0.5	10.5
-	63	FL (4) 20 S	1.5	1.5	1.5	1.5	1.5	1.5	1.5	9.5
-	15	Q (4) 20 S	0.5	0.5	0.5	0.5	0.5	0.5	0.5	16.5
-	263	FL (4) 20 S	0.5	2.0	0.5	2.0	0.5	2.0	0.5	12.0
-	238	Q (4) 28 S	0.5	0.5	0.5	0.5	0.5	0.5	0.5	24.5
-	111	FL (4) 30 S	0.5	0.5	0.5	0.5	0.5	0.5	0.5	26.5

IR		FLASH CODE	ON		OFF		ON		OFF		ON		OFF	
SWITCH	Controller		ON	OFF	ON	OFF	ON	OFF	ON	OFF	ON	OFF	ON	OFF
A														
-	221	Q (5) 7 S	0.3	0.7	0.3	0.7	0.3	0.7	0.3	0.7	0.3	0.7	0.3	2.7
-	310	Q (5) 9 S	0.5	0.5	0.5	0.5	0.5	0.5	0.5	0.5	0.5	0.5	0.5	4.5
-	237	Q (5) 10 S	0.3	0.7	0.3	0.7	0.3	0.7	0.3	0.7	0.3	0.7	0.3	5.7
-	232	FL (5) 12 S	0.5	1.5	0.5	1.5	0.5	1.5	0.5	1.5	0.5	1.5	0.5	3.5
-	276	FL (5) 16 S	0.5	1.5	0.5	1.5	0.5	1.5	0.5	1.5	0.5	1.5	0.5	7.5
-	95	FL (5) 20 S	0.5	0.5	0.5	0.5	0.5	0.5	0.5	0.5	0.5	0.5	0.5	15.5
-	159	FL (5) 20 S	0.8	1.2	0.8	1.2	0.8	1.2	0.8	1.2	0.8	1.2	0.8	11.2
-	158	FL (5) 20 S	1.0	1.0	1.0	1.0	1.0	1.0	1.0	1.0	1.0	1.0	1.0	11.0

IR		FLASH CODE	ON		OFF		ON		OFF		ON		OFF	
SWITCH	Controller		ON	OFF	ON	OFF	ON	OFF	ON	OFF	ON	OFF	ON	OFF
A														
-	253	Q (6) 10 S	0.3	0.7	0.3	0.7	0.3	0.7	0.3	0.7	0.3	0.7	0.3	4.7
-	175	FL (6) 15 S	0.3	0.7	0.3	0.7	0.3	0.7	0.3	0.7	0.3	0.7	0.3	9.7
-	127	FL (6) 15 S	0.5	1.0	0.5	1.0	0.5	1.0	0.5	1.0	0.5	1.0	0.5	7.0

IR		FLASH CODE	ON		OFF		ON		OFF		ON		OFF		ON		OFF	
SWITCH	Controller		ON	OFF	ON	OFF	ON	OFF	ON	OFF	ON	OFF	ON	OFF	ON	OFF	ON	OFF
A																		
-	110	VQ (6) + LFL 10 S	0.2	0.3	0.2	0.3	0.2	0.3	0.2	0.3	0.2	0.3	0.2	0.3	0.2	0.3	2.0	5.0
-	126	VQ (6) + LFL 10 S	0.3	0.3	0.3	0.3	0.3	0.3	0.3	0.3	0.3	0.3	0.3	0.3	0.3	0.3	2.0	4.4
-	47	Q (6) + LFL 15 S	0.2	0.8	0.2	0.8	0.2	0.8	0.2	0.8	0.2	0.8	0.2	0.8	0.2	0.8	2.0	7.0
-	46	Q (6) + LFL 15 S	0.3	0.7	0.3	0.7	0.3	0.7	0.3	0.7	0.3	0.7	0.3	0.7	0.3	0.7	2.0	7.0
-	62	Q (6) + LFL 15 S	0.6	0.6	0.6	0.6	0.6	0.6	0.6	0.6	0.6	0.6	0.6	0.6	0.6	0.6	2.0	5.8
-	258	FL (6 + 1) 15 S	0.35	0.65	0.3	0.65	0.3	0.6	0.3	0.6	0.35	0.65	0.3	0.65	0.3	0.65	1.0	7.95
-	292	FL (6) + LFL 15 S	0.4	0.8	0.4	0.8	0.4	0.8	0.4	0.8	0.4	0.8	0.4	0.8	0.4	0.8	2.0	5.8
-	262	FL (6) + LFL 15 S	0.5	0.5	0.5	0.5	0.5	0.5	0.5	0.5	0.5	0.5	0.5	0.5	0.5	0.5	2.0	7.0
-	143	VQ (6) + LFL 15 S	0.3	0.3	0.3	0.3	0.3	0.3	0.3	0.3	0.3	0.3	0.3	0.3	0.3	0.3	2.0	9.4

IR		FLASH CODE	ON		OFF		ON		OFF		ON		OFF		ON		OFF	
SWITCH	Controller		ON	OFF	ON	OFF	ON	OFF	ON	OFF	ON	OFF	ON	OFF	ON	OFF	ON	OFF
A																		
-	275	FL (3+5) 12.2 S	0.9	0.3	0.9	1.0	0.9	0.3	0.3	0.3	0.3	1.0	0.3	0.3	0.3	0.3	4.5	-
-	78	VQ (9) 10 S	0.2	0.3	0.2	0.3	0.2	0.3	0.2	0.3	0.2	0.3	0.2	0.3	0.2	0.3	0.2	5.8
-	94	VQ (9) 10 S	0.3	0.3	0.3	0.3	0.3	0.3	0.3	0.3	0.3	0.3	0.3	0.3	0.3	0.3	0.3	4.9
-	31	Q (9) 15 S	0.2	0.8	0.2	0.8	0.2	0.8	0.2	0.8	0.2	0.8	0.2	0.8	0.2	0.8	0.2	6.8
-	14	Q (9) 15 S	0.3	0.7	0.3	0.7	0.3	0.7	0.3	0.7	0.3	0.7	0.3	0.7	0.3	0.7	0.3	6.7
-	267	Q (9) 15 S	0.5	0.5	0.5	0.5	0.5	0.5	0.5	0.5	0.5	0.5	0.5	0.5	0.5	0.5	0.5	6.5
-	30	Q (9) 15 S	0.6	0.6	0.6	0.6	0.6	0.6	0.6	0.6	0.6	0.6	0.6	0.6	0.6	0.6	0.6	4.8
-	291	FL (9) 32.92 S	0.4	0.8	0.4	0.8	0.4	0.8	0.4	0.8	0.4	0.8	0.4	0.8	0.4	0.8	0.4	22.9

IR		FLASH CODE	ON		OFF		ON		OFF	
SWITCH	Controller		ON	OFF	ON	OFF	ON	OFF	ON	OFF
A										
MORSE CODE () INDICATES LETTER										
-	120	MO (A) 6 S	0.3	0.6	1.0	4.1				
-	123	MO (A) 8 S	0.4	0.6	2.0	5.0				
-	136	MO (A) 8 S	0.8	1.2	2.4	3.6				
-	184	MO (U) 10 S	0.3	0.7	0.3	0.7	0.9	7.1		
-	200	MO (U) 10 S	0.4	0.6	0.4	0.6	1.2	6.8		
-	216	MO (U) 10 S	0.5	0.5	0.5	0.5	1.5	6.5		
-	152	MO (A) 10 S	0.5	0.5	1.5	7.5				
-	137	MO (D) 10 S	5.0	1.0	1.0	1.0	1.0	1.0		
-	168	MO (A) 15 S	0.5	1.5	2.0	11.0				
-	248	MO (U) 15 S	0.6	0.3	0.6	0.3	1.4	11.8		
-	9	MO (U) 15 S	0.7	0.5	0.7	0.5	1.9	10.7		
-	25	MO (U) 15 S	0.7	0.7	0.7	0.7	2.1	10.1		
-	125	MO (B) 15 S	1.5	0.5	0.5	0.5	0.5	0.5	10.5	

Optional IR Remote Control

The IR remote is used to communicate with Sealite lighting products that have an IR sensor fitted. The remote control is used for the following functions:

- Flash Code: read the current flash code, configure a new flash code.
- Lamp Intensity: read the current lamp intensity, configure a new intensity level.
- Ambient Light Thresholds: read the current light thresholds, configure new ambient light thresholds.
- Perform a battery health check.

On receiving a valid key signal from the IR Remote, the light will flash once. The user should wait until the light responds to each keypress before pressing another key. If there is no response to the keypress after 3 seconds, it has not been detected by the light and the key can be pressed again.

If an invalid key is detected, the light will flash quickly 5 times. In this case, the command will have to be restarted.

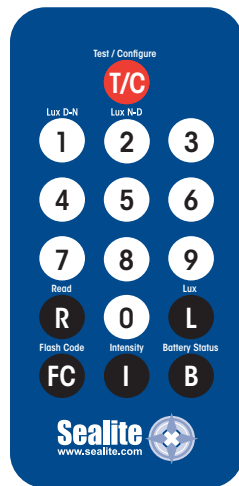

Sealite IR Controller / Universal Remote Compatibility

If you lose your Sealite IR Controller, the following Universal Remote Controller has been tested for compatibility: RCA Type RCR312WR programmed for Phillips TV Type Code 10054

Sealite Key	Universal Remote Key
T/C	Power
1	1
2	2
3	3
4	4
5	5
6	6
7	7
8	8
9	9
0	0
R	Channel+
L	Mute
FC	Volume+
I	Volume-
B	Channel-

IR Controller Functions

Test Mode / Configure



Pressing the T/C button for up to 5 seconds places the light in Test Mode. The light will flash once in response to the T/C button being pressed and then turn off.

Normal Operation

The light will return to normal operation once it has not detected a valid key press for 30 seconds. The light will flash once to indicate it is returning to normal operation.

Read

Pressing the Read followed by one of the configuration keys shall cause the light to flash the configured value.

Example Key Sequences:

R **FC** **T/C** The light flashes the 'IR Remote' number belonging to the currently set Flash Code. Refer to the Flash Code tables to match the 'IR Remote' flash number to the Flash Code.

R **I** **T/C** The light flashes the current intensity setting: 1 flash for 25%, 2 for 50%, 3 for 75% and 4 for 100%.

R **B** **T/C** The light flashes the current battery status.

R **L** **T/C** The light flashes the sunset level in Lux, followed by a 2 second gap, followed by the sunrise level. Levels are in the range of 1 to 9.

Flash Code

FC

This key sets the flash code on the light.

Example Key sequence:

FC 1 2 3 **T/C**

This sets the flash code to value 123. The light responds by flashing the flash code value.

Flash Code Numbers

The lamp flashes numbers as follows: Hundreds, Tens, Ones. A value of 125 will be flashed as: 1 flash, followed by a delay, 2 flashes, followed by a delay, 5 flashes.

The flash for number 0 is one long flash.

For example if the current Flash Code is set to 51 via the AB switches, the lamp will flash number 081.

For a flash code set to 01, the lamp will flash 001.

Intensity

This function sets the light intensity. Valid intensity values are 1 for 25%, 2 for 50%, 3 for 75% and 4 for 100%.

I

Example Key sequence:

I 1 **T/C**

This sets the light intensity to 25%.

Battery Status

B

This function reads the battery status. The response from the light is High Voltage: 4 flashes, Good Voltage: 3 flashes, Low Voltage 2 flashes, Cutoff Voltage or below: 1 flash.

Example Key sequence:

R **B** **T/C**

Operational Mode

Sets the Lanterns Operation mode:

- Dusk to Dawn ,
- Always On,
- Standby

Dusk to Dawn Mode: at Dusk the light sensors will turn on the light and then synchronise to every other light with the same selected flash code.

Always On: the light sensor is disabled and the light is turned on and then synchronised to every other light with the same selected flash code.

Standby Mode: manually forces the lantern to turn off, disables the GPS but with access to daylight it will still charge the battery pack.

R **B** **I** **T/C** Read Operation Mode

B **I** **1** **T/C** Set Operation Mode to Always on

B **I** **2** **T/C** Set Operation Mode to Standby Mode

B **I** **3** **T/C** Set Operation Mode to Dusk to dawn

Error / Acknowledge Indication

If the key sequence is invalid, or an out of bounds value is attempted to be set, the light flashes 5 times for 1 second. (The command then needs to be sent from the start.)

Example key sequence: (Set the intensity level to 5 – undefined.)

I **5** **T/C**

The light flashes 5 times for 1 second.

When a key sequence has been entered successfully the light will respond acknowledgement with a long 1 second flash.



Storage Mode (Advanced users)

For situations where the lantern is put into storage but with access to daylight, the IR Remote control can be used to configure the lantern into Storage Mode.

This mode manually forces the lantern to turn off, but with access to daylight it will still charge battery pack. However the lantern will not keep track of the date.

In Storage Mode, the GPS is disabled however the lantern will still respond to IR commands.

The lantern will automatically enter Storage Mode, if it is hibernating and it has not detected any light for 20 hours.

Enter Storage Mode

By pressing the following key sequence the lantern will enter Storage Mode:



The lantern will leave storage mode when exposed to daylight or if the power switch is turned OFF and ON again.

Configuration Settings

The intensity and flash codes can be changed using the switches on the lamp circuit board or with the IR Remote Control. The lamp intensity and flash code settings are set to the last detected change, carried out with the IR Remote Control or by changing the switch positions.

Example #1: If the intensity is set at 100% with the intensity switches, and is then set to 50% using the IR Remote Control, the intensity setting will change to 50%. If the intensity is then set to 75% using the switches, the new intensity value will be 75%.

In order to change intensity settings using the IR Remoter Control, the lamp must be powered.

The lamp can detect a change in switch settings if they are changed while the light is powered down.

Example #2: The flash code is set according to the switch settings: A=5, B = 1. The operator changes the flash code to 65 (A=4, B=1) using the IR Remote Control. The new flash code is now configured to A=4, B=1. The lamp is powered down and the operator changes the flash code switches to A=3, B=1 and powers on the light. The new flash code is now A=3, B=1. If the flash code is read from the light using the IR Remote Control, the lamp will flash 49 which is the corresponding number for switches A=3, B=1.

Use the IR Remote Control to read the current lamp intensity setting and flash code.



Maintenance and Servicing

Designed to be maintenance free, the SL-15 requires minimal attention, though the following maintenance and servicing information is provided to help ensure the life of your Sealite product.

1. **Cleaning Solar Panels** - occasional cleaning of the solar panels may be required. Using a cloth and warm soapy water, wipe off any foreign matter before rinsing the panels with fresh water.
2. **Battery Check** - inspection of batteries should be performed every two years (minimum) to ensure that the charger, battery and ancillary electronics are functioning correctly. Using a voltage meter, check that the battery voltage is at least 3.6 volts under 50mA load, and ensure all terminals are clear of foreign matter.

Replacing the battery

The SL-15 lantern is the only compact marine lantern with a double sealed battery compartment. This provides the user with the ability to change the battery after years of operation.

1. Remove the 4 x battery cover screws and lift the cover and battery out of the compartment to expose the adjustment plug.
2. Unscrew the adjustment plug.
3. Use a small flat bladed screwdriver to turn unit OFF.
4. Unscrew positive and negative battery leads.
5. Discard old battery in a safe manner. Please remember to recycle where possible.
6. Reattach positive and negative leads to new battery and then place back into case.
7. Switch lantern 'ON' via internal switch.
8. Cover the light, in darkness, for at least 30 seconds to activate the light sensor. Make sure the light is flashing correctly.
9. Uncover the light and wait at least 30 seconds to make sure the light turns off in daylight.
10. Insert the adjustment plug and replace the battery.
11. Replace the cover and secure using the 4 x screws.

Care must be taken to observe the polarity of the battery before the leads are re-connected, and ensure the replacement battery is correctly fitted. Always discard old batteries in a safe manner.

Long Term Storage Instructions (>4 weeks)

If light is required to be stored for longer than 4 weeks, please turn the light off using the internal ON/OFF switch (and external ON/OFF switch where fitted).

1. Remove the 4 x battery cover screws and lift the cover and battery out of the compartment to expose the adjustment plug.
2. Unscrew the adjustment plug.
3. Using a small flat bladed screwdriver switch the ON/OFF switch to the OFF position.
4. Insert the adjustment plug and replace the battery.
5. Replace the cover and secure using the 4 x screws. Do Not over tighten screws.
6. Repeat these steps to re-activate your light when it is removed from storage.

Note: When fitted with the optional EXTERNAL ON/OFF switch, for correct operation of the EXTERNAL switch, the INTERNAL switch must be set in the OFF position.

If the INTERNAL switch is set to the ON position, the operation of the EXTERNAL switch is bypassed and the lantern is ON.

All batteries will discharge over time and the rate of discharge is dependent on temperature. If the lantern is being stored in temperatures greater than 40°C the battery will discharge faster.

Please check battery every 3-6 months and recharge if necessary.

Trouble Shooting

Problem	Remedy
Lantern will not activate.	<ul style="list-style-type: none"> • Ensure internal switch (or external switch where fitted) is set to the 'ON' position. • Ensure lantern is in darkness. • Wait at least 45 seconds for the program to initialise in darkness. • Ensure switch setting is on a valid code (See <i>Flash Codes</i> section of this manual). • Ensure battery terminals are properly connected. • Ensure battery voltage is above 3.6 volts.
Timing codes will not change.	<ul style="list-style-type: none"> • Turn rotary switch several times to ensure contacts are clear.
Lantern will not operate for the entire night.	<ul style="list-style-type: none"> • Expose lantern to direct sunlight and monitor operation for several days. Sealite products typically require 1.5 hours of direct sunlight per day to retain full autonomy. From a discharged state, the lantern may require several days of operational conditions to 'cycle' up to full autonomy. • Ensure solar module is clean and not covered by shading during the day.

Optional ON/OFF Switch

ON/OFF Switch (SL-15-SW)

An optional external ON/OFF switch can be installed on request (additional charges will apply).

For correct operation of the EXTERNAL switch, the INTERNAL switch must be set in the OFF position.

If the INTERNAL switch is set to the ON position, the operation of the EXTERNAL switch is bypassed and the lantern is ON.

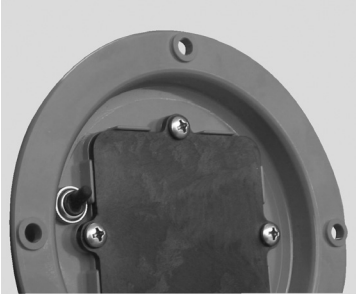

SL-15 Accessories



MC/02

Post mounting plate to suit standard base SL-15
50mm ID



MC/04

Post mounting stand
50mm OD post, 3-hole 200mm OD base pattern



MC/05

90 degree wall mounting stand
50mm OD



MC/09

Buoy mounting plate to affix SL-15 lantern to SL-B600, SL-B610 &
SL-B700 buoys

Sealite LED Light Warranty V2.2

Refer to www.sealite.com for warranty details.

