



Manual

Version
February 2021



ANDRENA SERIES

12V2.5Ah | 5Ah | 7.5Ah | 10Ah
15Ah(SC) | 20Ah(SC) | 25Ah



User Manual Andrena Series

This manual contains all the information necessary to install, use and maintain the Li-ion battery. We kindly ask you to read this manual carefully before using the product. In this manual, the Super B Andrena Li-ion power batteries will be referred to as the Li-ion battery. This manual is meant for the installer and the user of the Li-ion battery. Only qualified and/or certified personnel may install and perform maintenance on the Li-ion battery. Please consult the index at the start of this manual to locate information relevant to you.

During the use of the Li-ion battery, user safety should always be ensured, so installers, users, service personnel and third parties can safely use the Li-ion battery.

Copyright© Super B All rights reserved. Licensed software products are owned by Super B or its subsidiaries or suppliers, and are protected by national copyright laws and international treaty provisions. Super B products are covered by Dutch and foreign patents, issued and pending. Information in this publication supersedes that in all previously published material. Specifications and price change privileges reserved. Super B is a registered trademark of Super B.

For more information please contact:

Super B Lithium Power B.V.
Europalaan 202
7559 SC Hengelo (Ov)
The Netherlands
Tel: +31(0)88 00 76 000
E-mail: info@super-b.com
www: www.super-b.com

Table of content

1. Safety guidelines and measures	5
1.1. General	5
1.2. Disposal	5
1.3. Safety symbols and markings on product	6
2. Introduction	7
2.1. Product description	7
2.2. Intended use	7
2.3. Glossary of Terminology	7
2.4. Used symbols	8
3. Product specifications	8
3.1. Technical specifications	8
3.1.1. Electrical specifications	8
3.1.2. Mechanical specifications	8
3.1.3. Charge and discharge specifications	9
3.1.4. Temperature specifications	9
3.1.5. Compliance specifications	9
3.1.6. General product specifications	10
3.2. Environmental conditions	10
3.3. Required tools	10
3.4. Scope of delivery	10
3.5. Connections	11
3.6. Optional Components	11
4. Installation	12
4.1. General information	12
4.2. Unpacking	12
4.3. Preparing the Li-ion battery for use	12
4.3.1. Placement of the Li-ion battery	13
4.3.2. Connection wires	13
4.3.3. Connecting power cables with automotive type terminal	13
4.3.4. Connecting a charger to the Li-ion battery	14
4.4. Disconnecting a Li-ion battery	14
5. Battery use	15
5.1. General information	15
5.2. Charging	15
5.2.1. Charging rate	15
6. Inspection and cleaning	16
6.1. General information	16
6.2. Inspection	16



6.3. Cleaning	16
7. Storage	16
8. Transportation	17
9. Disposal and recycling	17
10. Troubleshooting	17
11. Warranty and liability	18

1. Safety guidelines and measures

1.1. General

- Do not short-circuit the Li-ion battery.
- Treat the Li-ion battery as described in this manual.
- Do not dismantle, crush, puncture, open or shred the Li-ion battery.
- Do not expose the Li-ion battery to heat or fire. Avoid exposure to direct sunlight.
- Do not remove the Li-ion battery from its original packaging until required for use.
- In the event of electrolyte leaking, do not allow the liquid to come in contact with the skin or eyes. If contact has been made, wash the affected area with water and seek medical advice.
- Always use a class 2 charger which is specifically provided for use with a Lithium Iron Phosphate battery (LiFePO4).
- Observe the plus (+) and minus (–) marks on the Li-ion battery and equipment and ensure correct use.
- Do not mix batteries of different manufacture, capacity, size or type.
- Keep the Li-ion battery clean and dry.
- Secondary batteries need to be charged before use. Always use the correct charger and refer this manual for proper charging instructions.
- Do not leave the Li-ion battery on prolonged charge when not in use.
- After extended periods of storage, it may be necessary to charge and discharge the Li-ion battery several times to obtain maximum performance.
- Retain the original product documentation for future reference.
- Disconnect the Li-ion battery from the equipment when not in use.
- Do not charge the Li-ion battery below 0°C.

1.2. Disposal



Dispose the Li-ion battery in accordance with local, state and federal laws and regulations.

Batteries may be returned to the manufacturer.







Do not mix with other (industrial) waste.

1.3. Safety symbols and markings on product

Several safety symbols and markings can be found on the product. These markings are displayed below. Never remove these markings!



The meanings of the symbols:

	Wear eye protection
	Refer to instruction manual/booklet
	Warning, corrosive substance
	Warning, explosive material
	No open flame, ignition source and smoking prohibited
	No children allowed

2. Introduction

2.1. Product description

The Andrena power batteries are light-weighted, compact and offer high performances. The Li-ion batteries are especially developed for motorsports. If you want to use it on road, please consult with Super B.

Please note that Li-ion batteries have to be treated differently from conventional lead-acid batteries. We kindly ask you to pay attention to the warnings as mentioned on the battery:

1. Risk of fire and burns when not used or treated correctly.
2. Do not open, crush, heat above 60°C or incinerate.
3. Follow manufacturer's instructions.
4. Avoid contact with electrolyte. In the event of an accident, flush with water.
5. Do not jumpstart.
6. Use correct charger.
7. Do not puncture or impact this battery.
8. Do not short battery terminals.
9. Do not reverse connect (polarity).
10. Do not operate battery beyond published maximum specifications.
11. This product can store fault conditions internally, like excessive charge current or deep discharge situations. Super B uses this information in the warranty process.

2.2. Intended use

The Andrena series Li-ion battery serves as a voltage source for starting combustion engines, which use a 12V board net. Also stationary applications which require a short and high peak current can benefit from using this Li-ion battery. In applications other than motorcycles it is required to use the SB BDB 250; an external under and overvoltage protector, to secure the Andrena Li-ion battery against under- and overvoltage with the lowest possible stand-by current. Never install multiple Li-ion batteries in series or parallel.

2.3. Glossary of Terminology

Endurance Life-cycle:	The products maximum lifespan, achieved by following the guidelines presented in this manual
Charge cycle:	A period of use from fully charged, to fully discharged, and fully recharged again
CCCV:	Constant Current - Constant Voltage
LiFeP04	Lithium Iron Phosphate

Table 1. Glossary of terminology

2.4. Used symbols

The following icons will be used throughout the manual:

- ⚠ Warning!** A warning indicates severe damage to the user and/or product may occur when a procedure is not carried out as described.
- ⚠ Caution!** A caution sign indicates problems may occur if a procedure is not carried out as described. It may also serve as a reminder to the user.

3. Product specifications

3.1. Technical specifications

3.1.1. Electrical specifications

	Andrena 12V2.5Ah	Andrena 12V5Ah	Andrena 12V7.5Ah	Andrena 12V10Ah	Andrena 12V15Ah	Andrena 12V20Ah	Andrena 12V15Ah-SC	Andrena 12V20Ah-SC	Andrena 12V25Ah
Nominal capacity	2.5Ah	5Ah	7.5Ah	10Ah	15Ah	20Ah	15Ah	20Ah	25Ah
Energy	32Wh	64Wh	96Wh	128Wh	192Wh	256Wh	192Wh	256Wh	320Wh
Nominal voltage	12.8V								
Open circuit voltage	13.2V								
Self-discharge	<3% per Month								
EqPb (Equals lead-acid battery)	5 to 7 Ah	10 to 12 Ah	12 to 20 Ah	20 to 32 Ah	40 to 60 Ah	70 to 100Ah	40 to 60 Ah	70 to 100Ah	100 to 130Ah

Table 2. Electrical specifications

3.1.2. Mechanical specifications

	Andrena 12V2.5Ah	Andrena 12V5Ah	Andrena 12V7.5Ah	Andrena 12V10Ah	Andrena 12V15Ah	Andrena 12V20Ah	Andrena 12V15Ah-SC	Andrena 12V20Ah-SC	Andrena 12V25Ah
Dimensions (LxWxH)	114 x 32 x 84mm/ 4.49" x 1.26" x 3.30"	114 x 62 x 84mm / 4.49" x 2.44" x 3.30"	120 x 82 x 98mm/ 4.72" x 3.23" x 3.86"	120 x 82 x 124mm/ 4.72" x 3.23" x 4.88"	120 x 82 x 181mm/ 4.72" x 3.23" x 7.13"	120 x 82 x 238mm/ 4.72" x 3.23" x 9.37"	249 x 96 x 141mm/ 9.80" x 3.78" x 5.55"	249 x 96 x 141mm/ 9.80" x 3.78" x 5.55"	249 x 96 x 141mm/ 9.80" x 3.78" x 5.55"
Weight	0.46 kg / 1.0 lbs	0.85 kg / 1.8 lbs	1.3 kg / 3.0 lbs	1.7 kg / 3.7 lbs	2.4 kg / 5.4 lbs	3.2 kg / 7.0 lbs	2.9 kg / 6.4 lbs	3.6 kg / 8.0 lbs	4.3 kg / 9.5 lbs
Ingress protection	IP 69								
Cell type / chemistry	Cylindrical - LiFePO4								

Table 3. Mechanical specifications

3.1.3. Charge and discharge specifications

	Andrena 12V2.5Ah	Andrena 12V5Ah	Andrena 12V7.5Ah	Andrena 12V10Ah	Andrena 12V15Ah	Andrena 12V20Ah	Andrena 12V15Ah-SC	Andrena 12V20Ah-SC	Andrena 12V25Ah
Charge method	CCCV								
Charge voltage	14.3V - 14.6V								
Max charge current	10A	19A	27A	37A	52A	66A	52A	66A	77A
End of discharge voltage	8V								
Discharge current continuous	40A	80A	120A	160A	240A	320A	240A	320A	385A
Discharge pulse current (1 sec)	136A (54C)	255A (51C)	375A (50C)	493A (49C)	708A (47C)	892A (45C)	708A (47C)	892A (45C)	1045A (42C)

Table 4. Charge and discharge specifications

3.1.4. Temperature specifications

	Andrena Series
Charge temperature	0°C to 55°C ¹ / 32°F to 131°F ¹
Discharge temperature	-30°C to 55°C / -22°F to 131°F
Storage temperature short term (<1 month)	-40°C to 60°C / -40°F to 140°F
Storage temperature long term (>1 month)	-10°C to 25°C / 14°F to 77°F
Relative humidity	10-90%

Table 5. Temperature specifications

¹Do not charge the Li-ion battery below 0°C / 32°F

3.1.5. Compliance specifications

	Andrena Series
Certifications	CE, FCC, UN 38.3
Shipping classification	UN 3480

Table 6. Compliance specifications

3.1.6. General product specifications

	Andrena 12V2.5Ah	Andrena 12V5Ah	Andrena 12V7.5Ah	Andrena 12V10Ah	Andrena 12V15Ah	Andrena 12V20Ah	Andrena 12V15Ah-SC	Andrena 12V20Ah-SC	Andrena 12V25Ah
Battery designation	4IFpR27/66	4IFpR27/66-2	4IFpR27/66-3	4IFpR27/66-4	4IFpR27/66-6	4IFpR27/66-8	4IFpR27/66-6	4IFpR27/66-8	4IFpR27/66-10
Cycle life*	>1000 (10C discharge, 100% DoD)								

Table 7. General product specifications

*The cycle life given above is an indication at 23°C. Battery lifespan depends strongly on temperature and the applied charging and discharging currents.

3.2. Environmental conditions

- ⚠ Warning!** The Li-ion battery may only be used in conditions specified in this manual. Exposing the Li-ion battery to conditions outside the specified boundaries may lead to serious damage to the product and/or the user. Use the Li-ion battery in a dry, clean, dust free, well ventilated space. Do not expose the Li-ion battery to fire, water, solvents or excessive heat.

3.3. Required tools

- 10mm Hexagon socket wrench

3.4. Scope of delivery

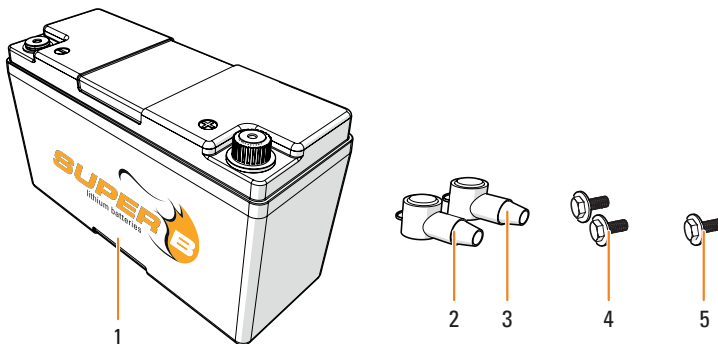

Figure 1. Scope of delivery

1. (1x) Andrena Li-ion Power battery
2. (1x) Terminal cover, Red
3. (1x) Terminal cover, Black
4. (2x) M6 bolt
5. (1x) Transportation terminal

3.5. Connections

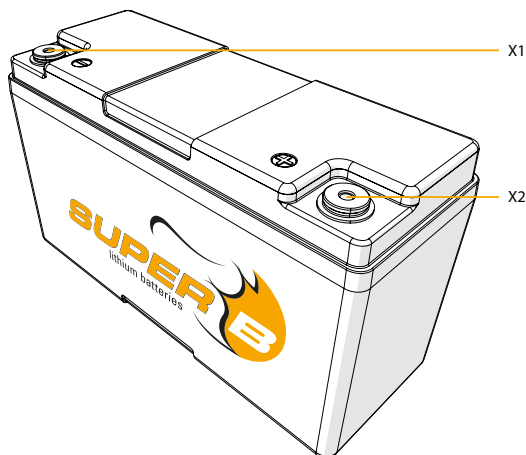

Figure 2. Connections

X1/X2: Battery Terminal for M6 bolt.

3.6. Optional Components

Description	Article name	EAN code
Battery Bracket Andrena 12V10Ah	SB Battery Bracket DC	8718531360228
Battery BracketAndrena 12V15Ah	SB Battery Bracket EC	8718531360235
Battery Bracket Andrena 12V20Ah	SB Battery Bracket FC	8718531360242
Battery Bracket Andrena 12V15Ah-SC, Andrena 12V20Ah-SC and Andrena 12V25Ah	SB Battery Bracket SC	8718531360327
5.0A Lithium Charger	Optimate charger 5.0 A/14.4V EU plug	5425006143905
5.0A Lithium Charger	Optimate charger 5.0 A/14.4V UK plug	5425006143905
5.0A Lithium Charger	Optimate charger 5.0 A/14.4V US plug	5425006143936
External under and overvoltage protector	SB-BDB-250	8718531361034

Table 8. Optional components

4. Installation

4.1. General information

- ⚠ **Warning!** Never install or use a damaged Li-ion battery.
- ⚠ **Warning!** Never short circuit the Li-ion battery.
- ⚠ **Warning! Connect to 12V systems only.** Never install multiple Li-ion batteries in series.
- ⚠ **Warning!** Do not reverse connect the power cables (polarity).

4.2. Unpacking

Check the Li-ion battery for damage after unpacking. If the Li-ion battery is damaged, contact your reseller or Super B. Do not install or use the Li-ion battery if it is damaged!

4.3. Preparing the Li-ion battery for use

- ⚠ **Warning!** Do not overcharge the Li-ion battery.
- ⚠ **Warning!** Do not operate the Li-ion battery beyond published maximum specifications.

Remove the transportation terminal before use and store it in a safe place. (Figure 3)

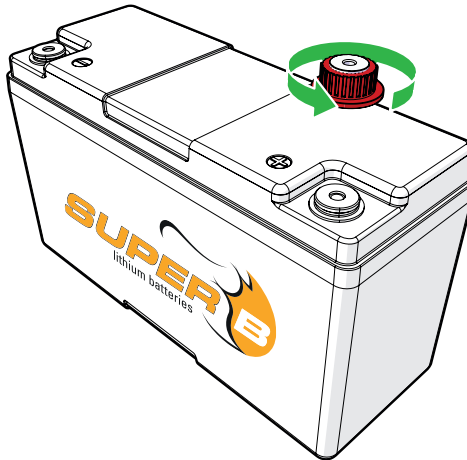

Figure 3. Remove the transportation terminal.

4.3.1. Placement of the Li-ion battery

Before it is used, the Li-ion battery must be positioned in such a way that it will not move around in its compartment during use.

Use appropriate brackets for mounting (see chapter 3.6 for optional components).

4.3.2. Connection wires

Use appropriate wire for the connection wires to prevent overheating and unnecessary losses.

4.3.3. Connecting power cables with automotive type terminal

1. Connect the load or charger to the X2 (+) terminal of the Li-ion battery (Figure 4).

- ⚠ **Warning!** Do not connect the (-) terminal first as this may lead to short circuits.
- 2. Connect the load or charger to the X1 (-) terminal of the Li-ion battery (Figure 4).
- 3. Ensure both contacts are tightened (M6 = 10Nm).
- ⚠ **Warning!** Avoid short circuit when using a wrench.
- 4. Place the terminal covers over the terminals. (Figure 5).

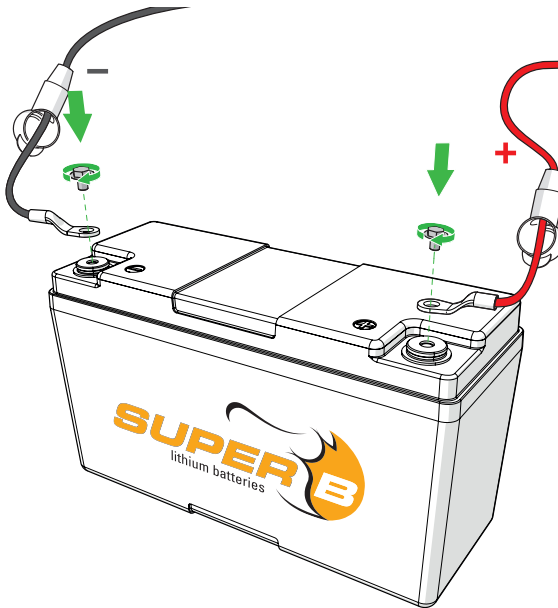

Figure 4. Connecting power cables to the Li-ion battery.

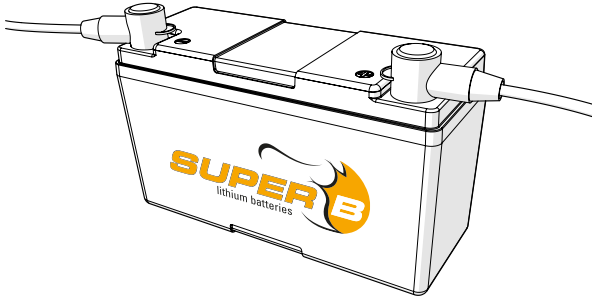

Figure 5. Place terminal covers over the terminals.

4.3.4. Connecting a charger to the Li-ion battery

- ⚠ Warning!** Ensure you have completed all the previous steps described in chapter 4 before connecting the Li-ion battery to the charger.

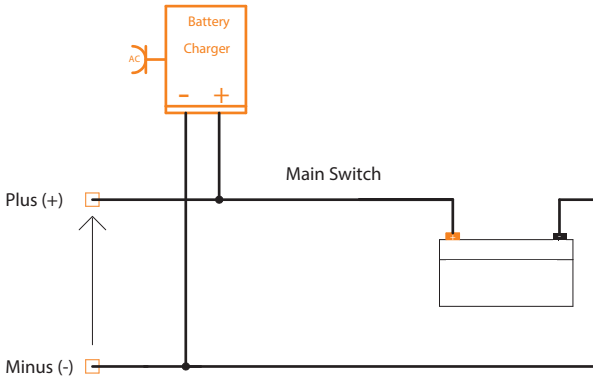

Figure 6. Connecting a charger to the Li-ion battery

4.4. Disconnecting a Li-ion battery

1. Disconnect the negative wire from the (-) terminal of the Li-ion battery.
2. Disconnect the positive wire from the (+) terminal of the Li-ion battery.

5. Battery use

5.1. General information

⚠ Warning! Follow the safety guidelines and measures of chapter 1.

5.2. Charging

⚠ Warning! Never overcharge the Li-ion battery, this will permanently damage the Li-ion battery.

⚠ Caution! Disconnect the charger from the Li-ion battery if it is not used for a long time.

⚠ Caution! To charge the Li-ion battery, use a Super B charger or charger which is suitable for charging Lithium Iron Phosphate batteries.

⚠ Caution! Charge the Li-ion battery before use.

1. Connect the charger to the Li-ion battery as described in paragraph 4.3.4
2. Charge the battery in case of an undervoltage shutdown or if the state of charge drops below 20% to preserve the lifespan of the Li-ion battery.

5.2.1. Charging rate

The Li-ion battery can be charged within 25 minutes. Displayed in Table 9 are the charge rates for the Li-ion battery at different charge currents. Always respect the indicated charge current.

	Charging rate	
	Charge current	
	Maximum*	Recommended charge**
Andrena 12V2.5Ah	10 A	2.5 A
Andrena 12V5Ah	19 A	5 A
Andrena 12V7.5Ah	27 A	7.5 A
Andrena 12V10Ah	37 A	10 A
Andrena 12V15Ah	52 A	15 A
Andrena 12V20Ah	66 A	20 A
Andrena 12V15Ah-SC	52 A	15 A
Andrena 12V20Ah-SC	66 A	20 A
Andrena 12V25Ah	77 A	25 A

Table 9. Charging rates at different charge currents

* Charge time: max 25 minutes

** Charge time: approximately 1 hour

6. Inspection and cleaning

6.1. General information

⚠ Warning! Never attempt to open or dismantle the Li-ion battery! The inside of the Li-ion battery does not contain serviceable parts.

1. Disconnect the Li-ion battery from all loads and charging devices before performing cleaning and maintenance activities (see paragraph 4.4).
2. Place the enclosed protective caps over the terminals before cleaning and maintenance activities to avoid the risk of a short circuit.

6.2. Inspection

1. Inspect for loose and/or damaged wiring and contacts, cracks, deformations, leakage or damage of any other kind. If damage to the Li-ion battery is found, it must be replaced by a professional. Do not attempt to charge or use a damaged Li-ion battery. Do not touch the liquid from a ruptured battery.
2. Consider replacing the Li-ion battery with a new one if you note either of the following conditions:
 - The Li-ion battery run time drops below 80% of the original run time.
 - The Li-ion battery charge time increases significantly.

6.3. Cleaning

If necessary, clean the Li-ion battery with a soft, dry cloth. Never use liquids, solvents, or abrasives to clean the Li-ion battery.

7. Storage

Follow the storage instructions in this manual to optimize the lifespan of the Li-ion battery during storage. If these instructions are not followed and the Li-ion battery has no charge remaining when it is checked, consider it to be damaged. Do not attempt to recharge or use it. Replace it with a new Li-ion battery.

The self-discharge of the Li-ion battery is <3% per month.

Storage instructions:

1. Charge the Li-ion battery to >50% of its capacity before storage.
2. Disconnect the Li-ion battery from all loads and, if present, the charging device.
3. Place the enclosed protective caps over the terminals during storage.
4. Charge the Li-ion battery to >50% of its capacity every 1 year.

8. Transportation

Always check all applicable local, national, and international regulations before transporting a Lithium Iron Phosphate battery.

Transporting an end-of-life, damaged, or recalled battery may, in certain cases, be specifically limited or prohibited.

The transport of the Li-ion battery falls under hazard class UN3480, class 9. For transport over water, air and land, the battery falls within packaging group PI965 Section II.

9. Disposal and recycling

Always discharge the Li-ion battery before disposal unless the battery is damaged. Use electrical tape or other approved covering over the Li-ion battery connection points to prevent short circuits.

Battery recycling is encouraged. Dispose the Li-ion battery in accordance with local, state and federal laws and regulations. Batteries may be returned to the manufacturer.

10. Troubleshooting

Problem	Possible situation	Solution
The Li-ion battery cannot be discharged.	The Li-ion battery is not installed properly.	Check the installation of the Li-ion battery.
	The cells within the Li-ion battery are damaged or the Li-ion battery is worn out.	Consult support Super B.
The Li-ion battery cannot be charged.	The Li-ion battery is not installed properly.	Check the installation of the Li-ion battery.
	The cells within the Li-ion battery are damaged or the Li-ion battery is worn out.	Consult support Super B.
The capacity of the Li-ion battery has decreased.	The cells within the Li-ion battery are damaged or the Li-ion battery is worn out.	Consult support Super B.

Table 10. Troubleshooting

11. Warranty and liability

11.1 Upon delivery the customer is obliged to immediately verify whether the products have been damaged during transport. In the event that any such damage has arisen, the customer must notify Super B thereof as soon as possible, in any event no later than three (3) days of delivery, by means of accurate, written statement, stating the damage and where possible a photograph. Failure to inspect the products and inform Super B within the stated time or the use of the products at any time shall be conclusive evidence that Super B has satisfactorily tendered delivery.

11.2 In the event that the customer demonstrates that any of the delivered products do not conform to the agreement, Super B (at its option, upon having received those products returned by the customer) has the option to either repair or replace such products by new products, or to refund the invoice value, exclusive of any dispatch costs.

11.3 Super B grants a three year limited warranty for damages caused by manufacturing defects starting at the time of delivery. Damages caused by manufacturing defects do not include damage resulting from (a) general wear and tear, (b) short circuit, (c) overcharging, (d) deep discharging, (e) overheating of Super B products (f) installation of the Super B product by persons unskilled to work with electro-technical devices or components, (g) any other wrongful use contrary to the Super B's user manual or the safety instruction, (h) any use contrary to the product specifications of that product; (i) any acts of force majeure.

11.4 The warranty period for parts of the product which have been repaired or replaced under the warranty, shall be twelve (12) months from the date of repair or delivery of the replacement.

11.5 Except as specified in the clause 11.3 and 11.4 Super B makes no warranty, whether express or implied, including without limitation any implied warranty of merchantability and fitness for a particular purpose or any warranty arising from any course of dealing, course of performance or usage of trade and specifically disclaims any representation or warranty that the product will meet customer's requirements, perform any specific function or achieve a desired result other than expressly stated by Super B in writing.

11.6 Any liability to the customer in any case ceases to apply in the event that the customer fails to notify Super B of the existence of the defect within ten (10) days of having discovered the defect, in writing, in order to enable Super B to investigate the damage. Some of Super B's products electronically store usage data, including charging/discharging data, in order to enable Super B to analyse such data retroactively when investigating damage.



11.7 Any liability of Super B for damage suffered by the customer is in any case limited to the invoice amount of the relevant products, unless such damage has been caused by gross negligence or willful misconduct of Super B. Super B can never be held liable for (a) damage caused by any of the circumstances mentioned in clause 11.3, leading to damage to the Super B products or to any other device located near those products, or (b) consequential damage, including but not limited to loss of profit, loss of production, loss of business interruption, loss of product and loss of capacity irrespective of the cause of such consequential loss or (c) goodwill.

11.8 To the extent that a court determines that the limitation of liability as meant in clause 11.7 cannot be invoked against a particular claim for damages by the customer, Super B's liability for loss of property, damage to property, and bodily injury (including death) caused by the application of those particular Super B products shall in any event be limited to the amount actually paid out by Super B's insurance company to Super B in accordance with the insurance cover of that insurance policy for that particular type of damage. Super B has taken out insurance against certain risks, as described in the respective insurance policies. These policies contain a usual limitation of insurance payment to be paid out to Super B if, and to the extent that, the event is a covered event.



For more information please contact:

Super B Lithium Power B.V.
Europalaan 202
7559 SC Hengelo (Ov)
The Netherlands

Tel: +31 (0)88 0076 000
E-mail: info@super-b.com
www: www.super-b.com

